



We've done it again. We took the groundbreaking Seakeeper 3 and made it even smaller. 25% lighter and 20% smaller to be exact. Specially designed for boats approximately 27-32 feet, the **Seakeeper 2** eliminates up to 95% of boat roll. Now even more people will be able to enjoy their time out on the water.

TECH SPECS

Rated Speed	9,000 RPM
Angular Momentum at Rated RPM	2,000 N-M-S
Max Anti-Rolling Torque at Rated RPM	5,249 N-M
Spool-up Time to Rated RPM	35 minutes (9,000 RPM)
Spool-up Time to Stabilization	24 minutes (7,650 RPM)
Spool-up Power	
DC Input	850 Watts Max
Operating Power	
AC Input	N/A
DC Input	300 - 650 Watts (Sea State Dependent)
AC Input Voltage	N/A
DC Input Voltage	12 VDC @ 75 Amps
Ambient Air Temperature	0° - 60° C (32° - 140° F)
Weight	414 lbs (188 kg)
Envelope Dimensions	Length x Width x Height 24.8 L x 25.5 W x 20.0 H (Inches) 0.630 L x 0.648 W x 0.508 H (Meters)
Noise Output	<68 dBC at 1 meter



PORT VIEW

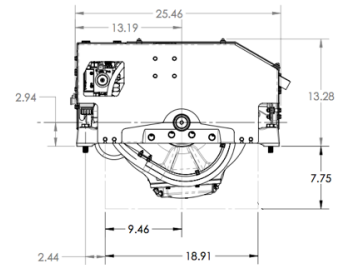

FRONT VIEW

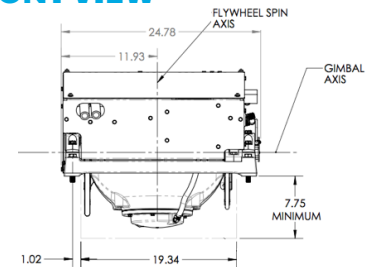

TOP VIEW

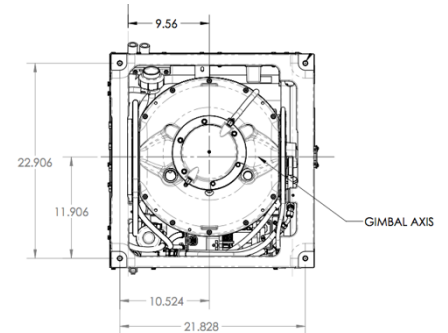

SEAKEEPER