

## Technical Data

### QVT 45

#### Generating set

##### Basic technical data

Engine Manufacture	KVT
Engine Model	E44SI
Number of cylinders	4
Cycle	Four stroke
Induction system	Natural Aspirated
Compression ratio	13:1/10.5:1(LPG)
Bore	105 mm (4.13 in)
Strok	127 mm (5.00 in)
Cubic capacity	4.4 litres
Direction of rotation (view from front)	Clockwise
Firing order	1, 3, 4, 2
Lube oil consumption at full load	0.03 kg/h
Alternator Manufacture	Leroy Somer
Alternator Model	LSA 42.3 L9
Phase	3 Phase
Voltage	400V
Assumed Power factor	0.8



##### Dimensions and Connections

Gas Connection 1" BSP

##### Overall dimensions

Height 2015 mm

Length 3250 mm

Width 1100 mm

Weight 890kg(approx.)

If the engine is to operate in ambient conditions other than those of the test conditions, suitable adjustments must be made for the changes. For full details, contact QES or KVT

General installation	Units			50 Hz					
				NG			BG (55% CH <sub>4</sub> )		
Fuel Type	-			NG			BG (55% CH <sub>4</sub> )		
Electrical output COP / Consumption 100%	kWe	kVA	M3/hr	45	56	15,6	40	50	24,1
Electrical output COP / Consumption 75%	kWe	kVA	M3/hr	34	43	12,1	30	38	19,0
Electrical output COP / Consumption 50%	kWe	kVA	M3/hr	23	29	9,0	20	25	13,8
Electrical output COP / Consumption 25%	kWe	kVA	M3/hr	12	15	5,5	10	13	9,0
Exhaust gas outlet temperature (approx)	°C			640			660		
Voltage	V			400			400		
Power factor	pf			0.8			0.8		
Current	A			119			104		
Actual alternator efficiency	%			94.6			94.6		

Caution: The airflows shown in this table will provide acceptable cooling for an open power unit operating in ambient temperatures of up to 53 °C (127 °F) or 46 °C (114.8 °F) if a canopy is fitted. If the power unit is to be enclosed totally, a cooling test should be done to check that the engine cooling is acceptable. If there is insufficient cooling, contact us.

### Construction

- Rigid base frame made of profiled steel.
- Direct coupled engine and generator assembly with flexible drive plate.
- Engine generator assembly flexibly mounted on the base frame.
- Electrical equipment installed in a sheet steel cabinet that forms an integral part of the canopy.
- Air movement within the canopy controlled by an engine driven fan.
- All connection points at one end of the canopy.
- Primary exhaust silencer mounted within the canopy with a vertical exit at the end.

### Canopy

- Highly effective sound enclosure in packs of sheet steel construction, powder coated. Air passages acoustically lined and waterproof.

### Exhaust System

- Steel mounted within the canopy.
- The lubrication system comprises a wet sump system with full flow oil pump.

### Control Panel

- Sheet metal enclosure mounted within and forming an integral part of the canopy (1000x800x210mm). PLC based system enables auto and manual control for start/stop, voltage control, mains synchronization, load control, Remote control Data access through Ethernet, HMI graphic interface to view and set parameters.

### Engine control

- Start/stop, engine speed control, monitoring for engine coolant inlet and outlet temperatures and exhaust temperature.

### Alternator control

- Control of the alternator mounted AVR for voltage output, power output and Power Factor.

### Emergency stop

- Canopy mounted push button with external link.

### Emissions

- Standard 3 way catalyst
- NOx emission <10 mg/Nm<sup>3</sup>

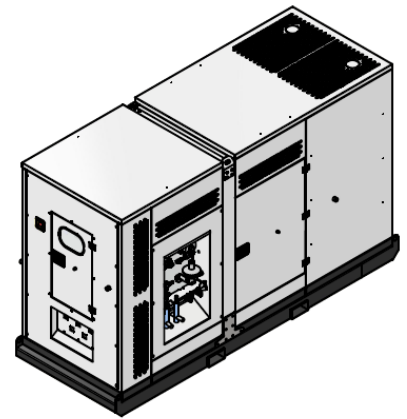
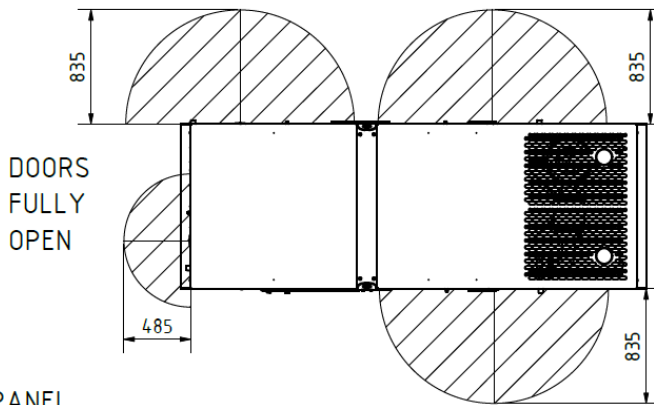

ISOMETRIC VIEW

CONTROL PANEL

EMERGENCY STOP

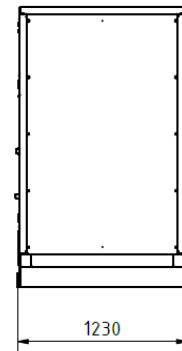
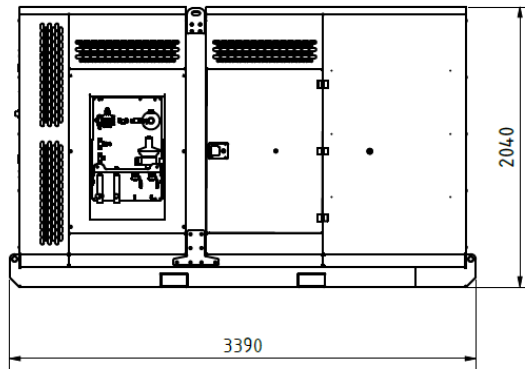
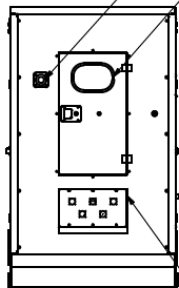

POWER CABLE ENTRY - EXIT



United Kingdom:

QUANTUM ES  
Geat Mill Road, Merthyr Tydfil CF48 3TF  
Tel: +44 - 1685 353270  
Email: [sales@qvtpower.com](mailto:sales@qvtpower.com)

The Netherlands:

QVT POWER  
Keenweer 62, 3316 KA Dordrecht  
Tel: +31 - 78 632 66 00  
Email: [info@qvtpower.com](mailto:info@qvtpower.com)

